

Range: Deck-mounted mixer sensor tap
Ref: 55375 - PRESTO NOVA

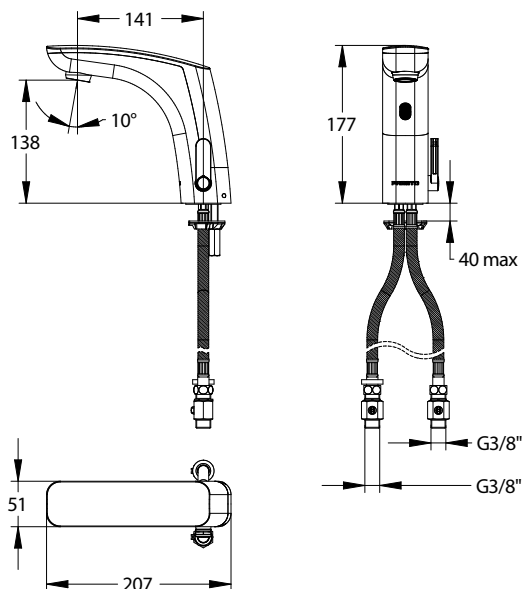

> Working pressure :

- 1 to 5 bar

> Flow :

- 3 l/min with integrated flow limiter
- High quality anti-limescale aerator
- Anti-water-hammering design

> Hydraulic supply :

- G 3/8" (12x17)

> Power supply :

- Integrated 6V CRP2 lithium battery

> Material and colour finish :

- Injected molded metal body and cover
- Chrome finishing

> Thermal resistance :

- Resistant to a temperature of 75°C for 30 minute thermal shocks

> Security :

- Temperature limiting system to avoid any risk of scalding
- Anti-overflow security time is set to 30 seconds
- Anti-blocking system preventing the water to flow continuously

> Delivered with :

- 1 Brass clamping nut
- 1 Gasket and 1 Washer
- 2 PEX Hoses with revolving nuts and NF check valves
- 2 MM G 3/8" (12x17) Stop valves
- 2 Filter gaskets
- 1 Self-adhesive sticker
- Instruction manual

> Standards & approvals :

- Molded chrome-plated body in accordance with EN 12540
- Brass in accordance with NF EN1982, EN12164, EN12165
- 200-hour neutral salt spray resistant (NSS) in accordance with NF ISO 9227

