

Range: Safety thermostatic mixing valves

Ref: 29002 - Thermostatic mixing valve with temperature locking

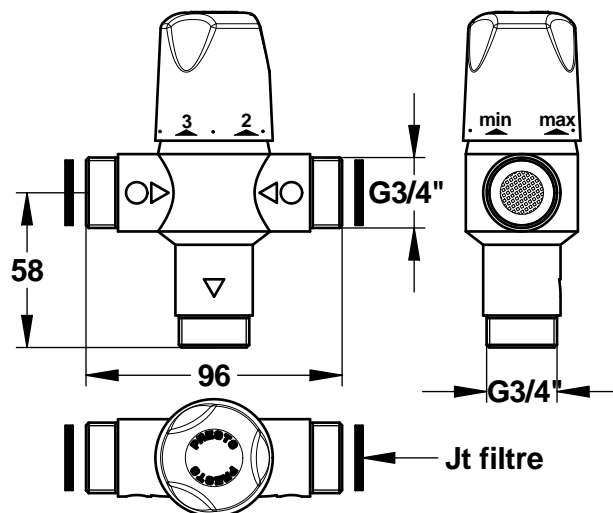

> Flow :

- Out Flow rate of mitigated water at 3 bar : 57L/min
- Minimal out flow rate of mitigated water : 5L/min

> Temperature :

- Temperature range : 30 to 65°C
- Temperature, hot water inlet : 85°C max
- Minimum differential temperature : 10°C (Between hot water inlet and mixed outlet)
- Stability of mixed water temperature : +/- 2°C

> Hydraulic supply :

- G 3/4" Inlet and outlet
- Marked hot water (H) and cold water (C)

> Thermal resistance :

- Designed to withstand thermal shocks at temperatures over 75°C during 30 min

> Security :

- Anti-scald system: flow is immediately stopped if the cold water is cut off
- Possibility of blocking the internal temperature

> Delivered with :

- 2 Filter gaskets
- 2 NF check valves
- Instruction manual

> Standards & approvals :

- 200-hour neutral salt spray resistant (NSS) in accordance with ISO 9227
- Brass body in accordance with EN 1982, EN 12164, EN 12156

Ce document n'est pas contractuel ; nous nous réservons le droit de modifier les caractéristiques de nos produits sans préavis. Toutes nos marques et tous modèles sont déposés.

